

Fact Sheet

iS30 weighing terminal

BIZERBA

The multi-talent among the weighing terminals - the iS30 weighing terminal impresses in terms of its large fully graphic display and its compact design. With its comprehensive range of interfaces and software programs this terminal impresses in all application areas.



More information
High performance
with a wide range of
solutions and options.

Specifications	Facts	Details
Housing	Front: Plastic Housing: stainless steel Wall / table mounting VESA 100 mounting option	Polyamide glass fiber reinforced 1.4301
Dimensions (mm):	w/o table-top/wall mounting with table-top/wall mounting	300 x 230 x 99 mm (W x H x D) 345 x 267 x 150 mm (W x H x D)
Auxiliary power	Mains supply 100 - 240 V 24 V AC / DC 24 V DC, rechargeable battery	50/60 Hz
Protection class	IP65 IP69	according to DIN 40050 (EN 60529)
Ambient temperature	Operation metrologically approved storage/transport	-10 °C to +40 °C -20 °C to +60 °C
Display	Fully graphic TFT display with white LED backlighting	Size 5.7" Resolution 320 x 240 pixels Display field 115 x 86 mm
Membrane keyboard with a total of 39 keys	Six keys for basic weighing functions Four function keys with two arrow keys Four application keys Numeric keypad for alphanumeric input Navigation keys Stand-by key Scale shift key	Info, zero setting, tare, delete tare, recording and manual tare Functions can be freely assigned Input of process data With keys C, decimal point, shift key and Enter With OK key, ESC and quick access key Switch terminal on/off/ Switching between scale 1 and 2
Standard interfaces	Ethernet RS232 4E / 4A	10 / 100 Mbit galvanically not isolated static inputs and outputs
Scale interface	Weighing module 1	Analog scale Digital scale Pesa scale
EC type approval	D08-09-028, 4th revision	PTB-1.12-4067644

Options	Facts	Details
Interfaces	RS232 RS232, 500mA RS422 Field bus Analog output USB 8 inputs / 8 outputs - expansion I/O power supply	galvanically isolated galvanically isolated Profibus DP Slave, 12 MBit Profinet IO 16 bit Master total of 12 inputs / 12 outputs per weighing module Internal, 12 V, 500 mA, galvanically isolated
Second scale interface	Weighing module 2	Analog digital converter for strain gauge load cells Pesa interface Precision scale connection RS232 MP8-4 (200ms)
ES for verified application	Metrologically approved data storage Basic	incl. SD card
Application programs, program licenses	Counting Tolerance control Statistics Dosing Dynamic calibration In-motion weighing Recording database Data input devices Data output devices Field bus	SW program counting SW program tolerance control SW program statistics SW program single-component dosing / filling Only in connection with Bizerba conveyor technology Only in connection with Bizerba conveyor technology For EDP / printer Connection volume measuring device, scanner ... Connection of printer, remote display ... Profibus DP, Profinet IO
Rechargeable battery	Battery box 24 V	24 V DC, capacity 10 Ah, stainless steel housing with handle, protection IP65, connection via flange connector, operating time approx. 12-35 h, depending on upgrade stage
Charger	Charger for battery box 24 V	Power connection 220/240V, 50 Hz, 24 V European standard size plug, IP20 protection
Battery holder	Stainless steel version	
Measuring cable	3 m, 6 m, 10 m or running meter up to 50 m	Optionally available as pluggable measuring cable
Data and control cables	Different data and control cables, 3 m, 6 m, 10 m or running meter	
Control panel installation	installation variant in control panel Stainless steel 1.4301 Protection class IP65	W = 330 mm, H = 287 mm, D = 123 mm
Control panel mounting "retrofitting"	Compatible with control panel mounting ST terminal Stainless steel 1.4301 Protection class IP65	W = 367 mm, H = 287 mm, D = 128 mm
Ex version	iS30-Z2	For use in Ex zone 2/22
Column	Stainless steel column	1.4301
Protective cover	Polyurethane	Walopur 2201 U

Infographic



Symbols



Protection Class IP65



Protection Class IP69



Strain gauge load cell connection



Precision scale connection



String technology connection



Ex-Zone 2/22



Housing in stainless steel

Dimensions

detail of control panel: new installation

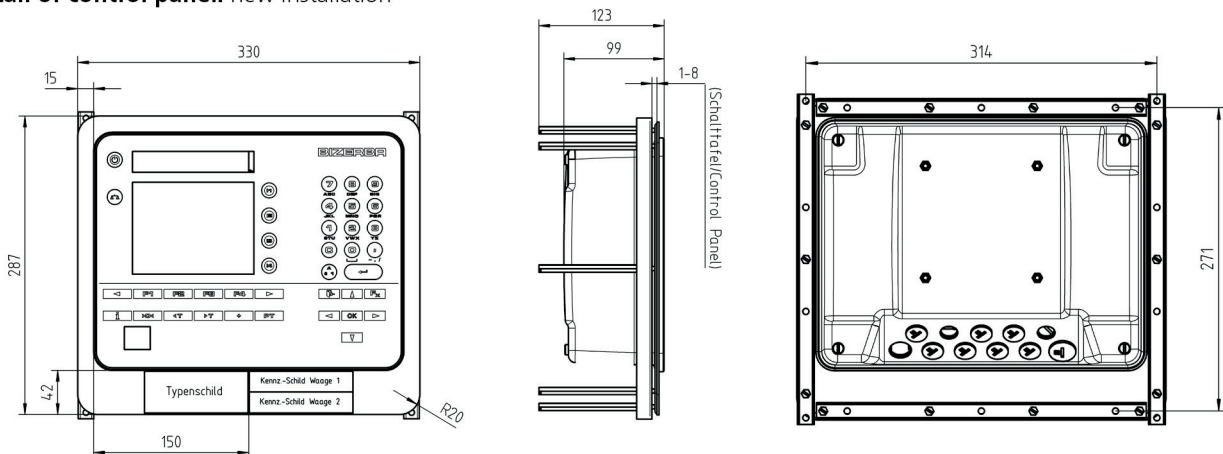

detail of control panel: exchange of industrial terminal ST for iS30

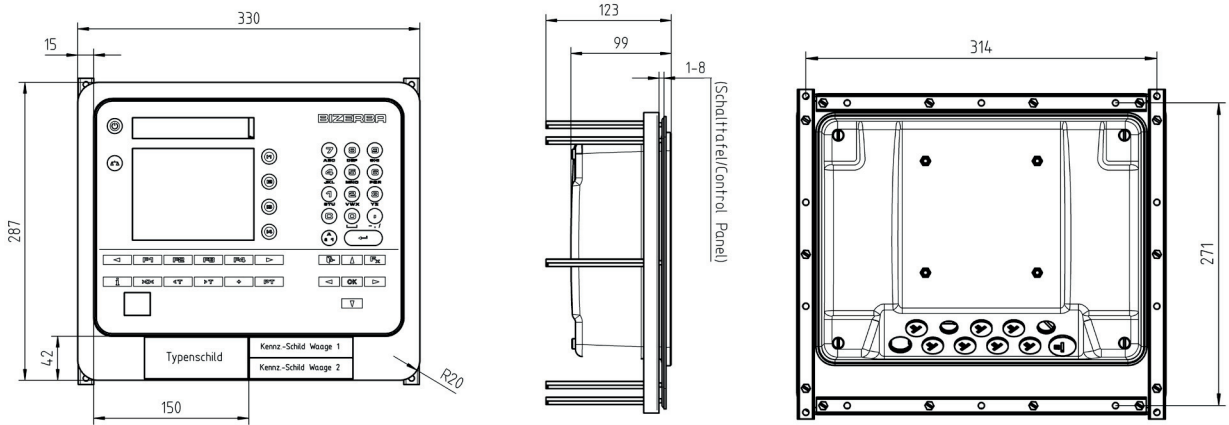

Bizerba SE & Co. KG
 Wilhelm-Kraut-Straße 65
 72336 Balingen
 Germany
 T +49 7433 12-0
 F +49 7433 12-2696
 marketing@bizerba.com

www.bizerba.com