

Fact Sheet

XC II 300 Pro

BIZERBA

Modern PC technology in a compact design is what the X-Class II Pro series stands for. This multifunctional device allows convenient, intuitive and fast operation via touchscreen. Enjoy more performance due to a large RAM. All models are provided with a powerful Intel® Quad Core processor. Ideally suitable for new features or individual requirements.



More information
High performance
with a wide range of
solutions and options.

Specifications	Facts	Details
Color	Anthracite gray	RAL 7016
Operator display	10.1" touch TFT	Resolution: 1,024 x 600 (WSVGA) LED backlit Resistive 5-wire touch technology Infinitely inclinable: adjustable viewing angle
	15.6" touch TFT	Resolution: 1,366 x 768 (HD/WXGA) LED backlit Resistive 5-wire touch technology Infinitely inclinable: adjustable viewing angle
Customer display	No customer display	
	7" TFT	Resolution: 800 x 480 LED backlit
	10.1" TFT	Resolution: 1,024 x 600 (WSVGA) LED backlit
Operating system	Windows 10 IoT Enterprise 2016 LTSB	64 bit Windows
	BizLPOS3 OpenSuse® ≥ 42.1 Leap Kernel 4.2	64 bit Linux
Application software	RetailPowerScale	Bizerba scale software, compatible with Retail-Framework products
	RetailIntegratorsKit (RIK)	3rd-party software
Processor	Intel® Celeron® Processor N3160 Quad Core	Clock rate of up to 2.24 GHz L2 cache: 2 MB Instruction set: 64 bit Integrated graphics card: Intel® HD Graphics 400
Working memory	DDR3	4 GB RAM
Mass memory	SSD	60 GB, optionally 120 GB
Printer	3" label printer	print speed up to 150 mm/s, depending on the paper used
	3" receipt / linerless printer	Up to 3"/76 mm paper width, 200 dpi *Not recommended for industrial labeling
External additional printer	Usage of the Bizerba power supply unit	KF 3" receipt / linerless printer
	RSP 28 allows to use the following printers of the K-Flex series as external additional printer.	KF 3" label printer KF 2" L Compact receipt / linerless printer

Interfaces	2 x USB 3.0 2 x USB 2.0 2 x COM LAN Audio output Cash register drawer connection (COM)	Super speed High speed DSUB, RS232 RJ45, GBit LAN 3.5 mm jack RJ12
Weighing ranges	Connection of external load receptors	Weighing ranges up to 150 kg
Temperature range	-10 °C to +40 °C	
Power consumption	In stand-by 2.4 W During operation typically 20 W	Energy saving thanks to use of Wake on LAN
Net weight of device	XC II 300 Pro (10.1"/no customer display)	Approx. 10.5 kg
Software extensions	RetailApps Software modules: Cash register, scanning, e-cash, inventory, shrink re-weigh, returns, delivery note, return delivery, cash invoice, order, sum QR barcode, Content Flash, proof of origin, time registration, video journal, RetailConnect	Extra software function per RetailApps Extra software functions per module
WLAN modules	BWLC USB	Bizerba Wireless LAN Client 802.11 a/b/g max. 54 MBit/s USB WLAN stick, no floating sales mode possible 802.11 a/b/g/n max. 300 MBit/s

Info graphics



Dimensional drawings

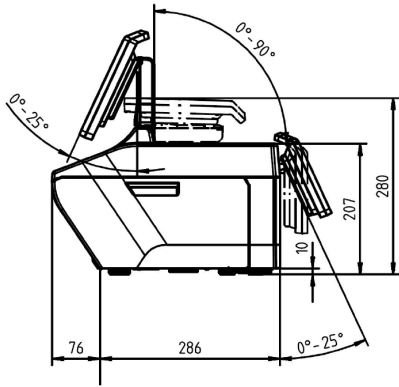

XC II 300 Pro side view (10.1"/7")

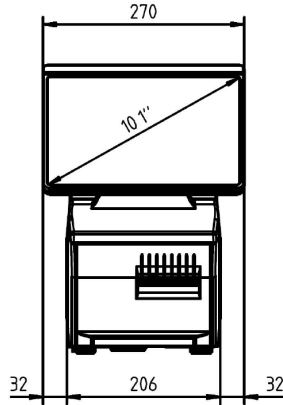

XC II 300 Pro operator side (10.1")

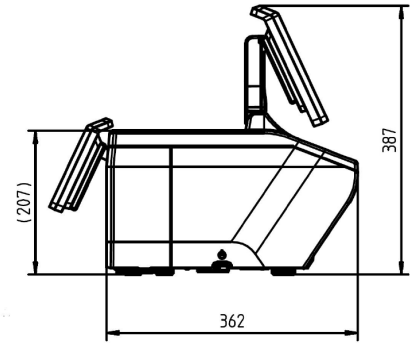

XC II 300 Pro side view (10.1"/7")

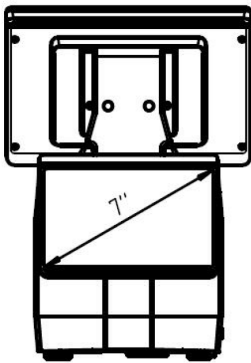

XC II 300 Pro customer side (10.1"/7")

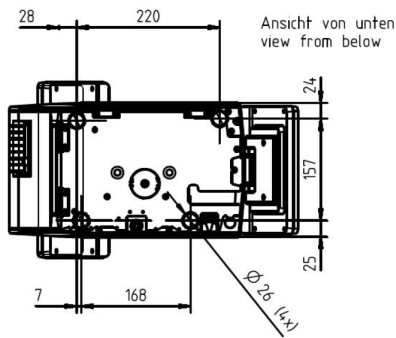

XC II 300 Pro bottom view (10.1"/7")

Bizerba SE & Co. KG
 Wilhelm-Kraut-Straße 65
 72336 Balingen

T +49 7433 12-0
 fax: +49 7433 12-2696
 marketing@bizerba.com

www.bizerba.com