

# Data Sheet

## iL Special 450WSF/MP

# BIZERBA

*Integrated in the automatic overhead track system the conveyorized overhead rail scale iL Special 450WSF/MP shows all its strengths: A robust design, quick and precise weighing results and a high throughput.*



**More information**  
High performance  
with a wide range of  
solutions and options.

### Product description

In combination with weighing terminal iS30 or iS50 the iL Special 450WSF/MP exactly determines the weight values in dynamic operation and forwards them to higher-ranking systems. The weighing rail with special conveyor chain, sliding guide, chain tensioning device and drive motor guarantees optimal, dynamic weighing.

Application areas of the iL Special 450WSF/MP:

- Goods receiving and goods dispatch
- Slaughtering
- Classification
- Cold room in/out
- Weighing of hams
- Cutting in/out
- Dispatch

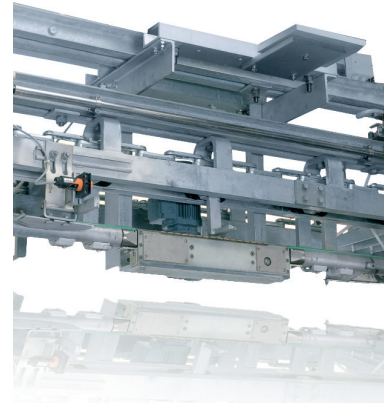

iL Special 450WSF/MP

### Highlights

- Robust design for harsh industrial applications in the meat area
- Load capacity up to 450 kg
- High protection type
- Independent conveying system incl. control cabinet
- Maintenance-free and service-friendly construction
- Easy integration in tubular rail systems
- Almost shock-free feeding and discharge of product
- Flexible weighing rail lengths between 560 mm and 870 mm, further weighing rail lengths upon request
- Highest precision due to Bizerba bending ring load cells

### Options

- Various dimensions with weighing rail lengths 560 mm, 660 mm, 710 mm, 870 mm and for projects also 410 to 1,200 mm
- Tubular rail connection steel tube or steel tube with plastic interior
- Version with one or two light sensors
- Weighing terminal iS30 or iS50 with Dynamic weighing license
- Control cabinet with integrated frequency converter

### Bizerba GmbH & Co. KG

Wilhelm-Kraut-Straße 65  
72336 Balingen  
Germany  
T +49 7433 12-0  
F +49 7433 12-2696  
marketing@bizerba.com

[www.bizerba.com](http://www.bizerba.com)